

MIPI-60-34-38 converter v. 1.2

This material, including documentation and any related computer programs, is protected by copyright controlled by Nokia. All rights are reserved. Downloading and copying of the material for use with the Fido tracebox is permitted. Redistribution of any or all of this material requires a prior written consent of Nokia. This material also contains confidential information, which may not be disclosed to others without the prior written consent of Nokia.

MIPI-60-34-38 overview

The MIPI-60-34-38 converter connects debug and trace systems designed for targets equipped with MIPI 34-pin FTSH or 38-pin MICTOR connector to targets equipped with MIPI 60-pin QSH connector.

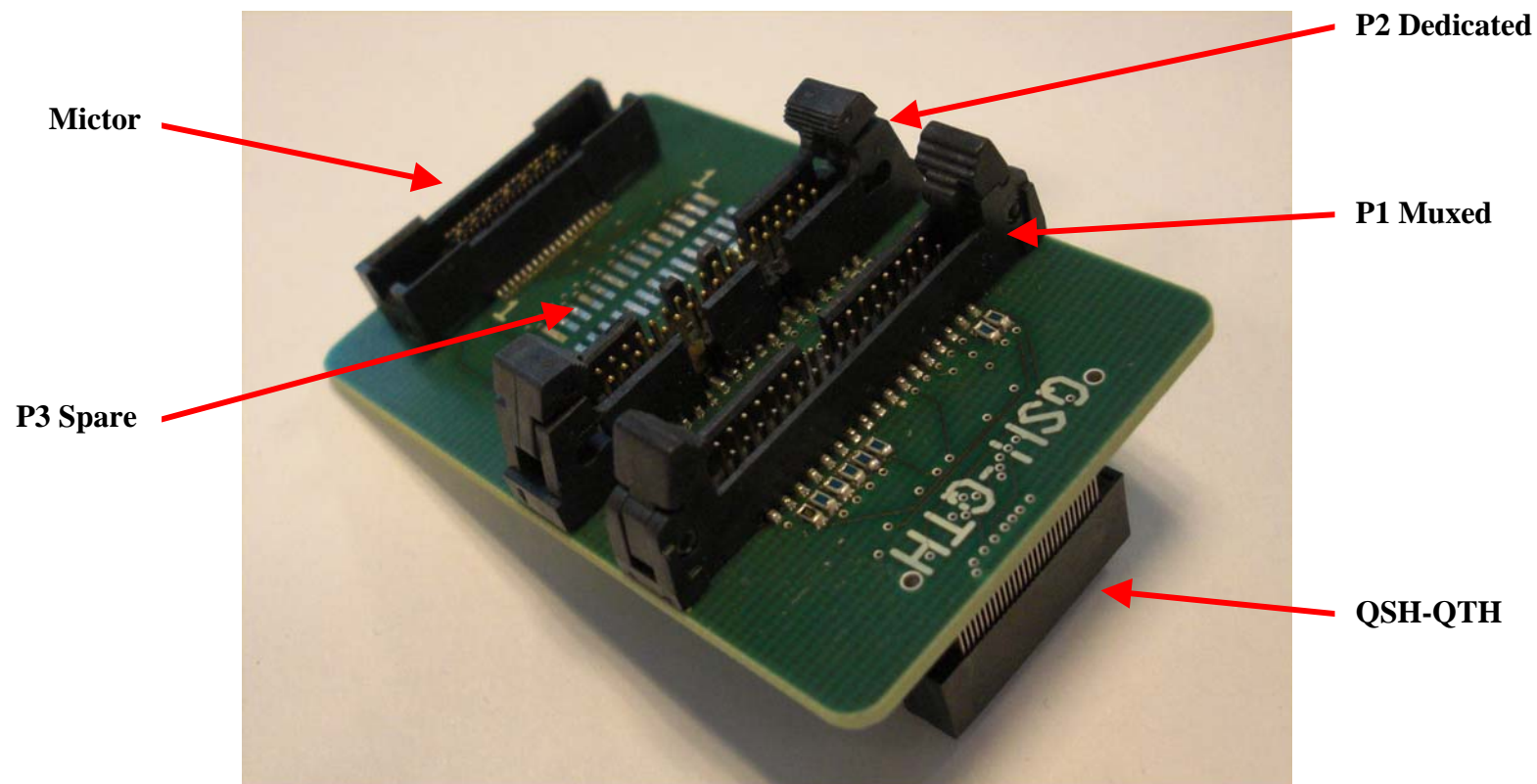

The MIPI 34-pin FTSH trace cable should be connected to P1 or P2 connector depending on the trace pin set (muxed, TRC_DATA[0][1...4] or dedicated, TRC_DATA[2][0...3]) used in QSH connector.

The optional P3 Spare connector is used to connect the MIPI 34-pin cable with target trace signals TRC_DATA[0][20...24] (pins 18, 20, 22 and 24). The MICTOR connector is for connecting to trace signals TRC_DATA[0][1...8] (pins 19,21,23,25,27,29,31,33) . The JTAG signals are led to all the connectors except P3 Spare.

The MIPI-60-34-38 converter design relies on the MIPI standard /1/ for the QSH connector. Its analogue is the LA-3769 Lauterbach converter /2/. There are, however, some differences:

- As concerning the way how the QTH connector is physically oriented, the MIPI-60-34-38 converter follows the MIPI standard but LA-3769 does not.
- By default, the MIPI-60-34-38 converter provides trace line on the QSH pin 19-33 for the both MICTOR and FTSH P1 connectors. LA-3769 offers these lines for MICTOR only.
- The JTAG signals are routed to the P1, P2 and MICTOR connectors. On LA-3769 JTAG signals are routed to the Probe1 connector and optionally to MICTOR.
- MIPI-60-34-38 supports the dedicated trace lines QSH pin 38-44 (TRC_DATA[2][0...3]), 60 (TRC_CLK[2]) and 54 (UART[2]) on a separated FTSH P2 connector. It is also supported on LA-3769 Probe2 connector but there pin 14 is used as trace clock and 46 as reverse UART signal.
- When the P3 connector is mounted then MIPI-60-34-38 supports the tracing from QSH pins 18-24 (TRC_DATA[0][20...24]). This is routed also on the LA-3769 to its Probe1 connector.

The QSH VREF_DEBUG and QSH VREF_TRACE reference voltages are separated and the user can select what is the setting for P2 and P3 VIO (pin 34). If the QSH VREF_DEBUG and QSH VREF_TRACE voltages are on different levels, take care not to shortcut them.

On the P2 and P3 connectors VIO is by default set to QSH VREF_TRACE. To change this setting to QSH VREF_DEBUG, move the resistors:

- On the P2 connector move the R23 resistor to position R12.
- On the P3 connector move the R25 resistor to position R24.

The muxed trace signal on the QSH pins 19,21,23,25 and 13 is routed to the both P1 and MICTOR connectors. Would you need to improve the signal quality, cut off the not-used connections between QSH and the connector(s). For that remove the resistors:

- To disconnect the muxed trace from the P1 connector: remove the R1,R3,R5,R7 and R9 resistors.
- To disconnect the muxed trace from MICTOR connector: remove the R2,R4,R6,R8 and R10 resistors.

MIPI-60-34-38 converter was successfully tested with ETM tracing on working speed up to 250MHz.

MIPI-60-34-38 pin layout

This diagram shows how the signals are routed to the connectors:

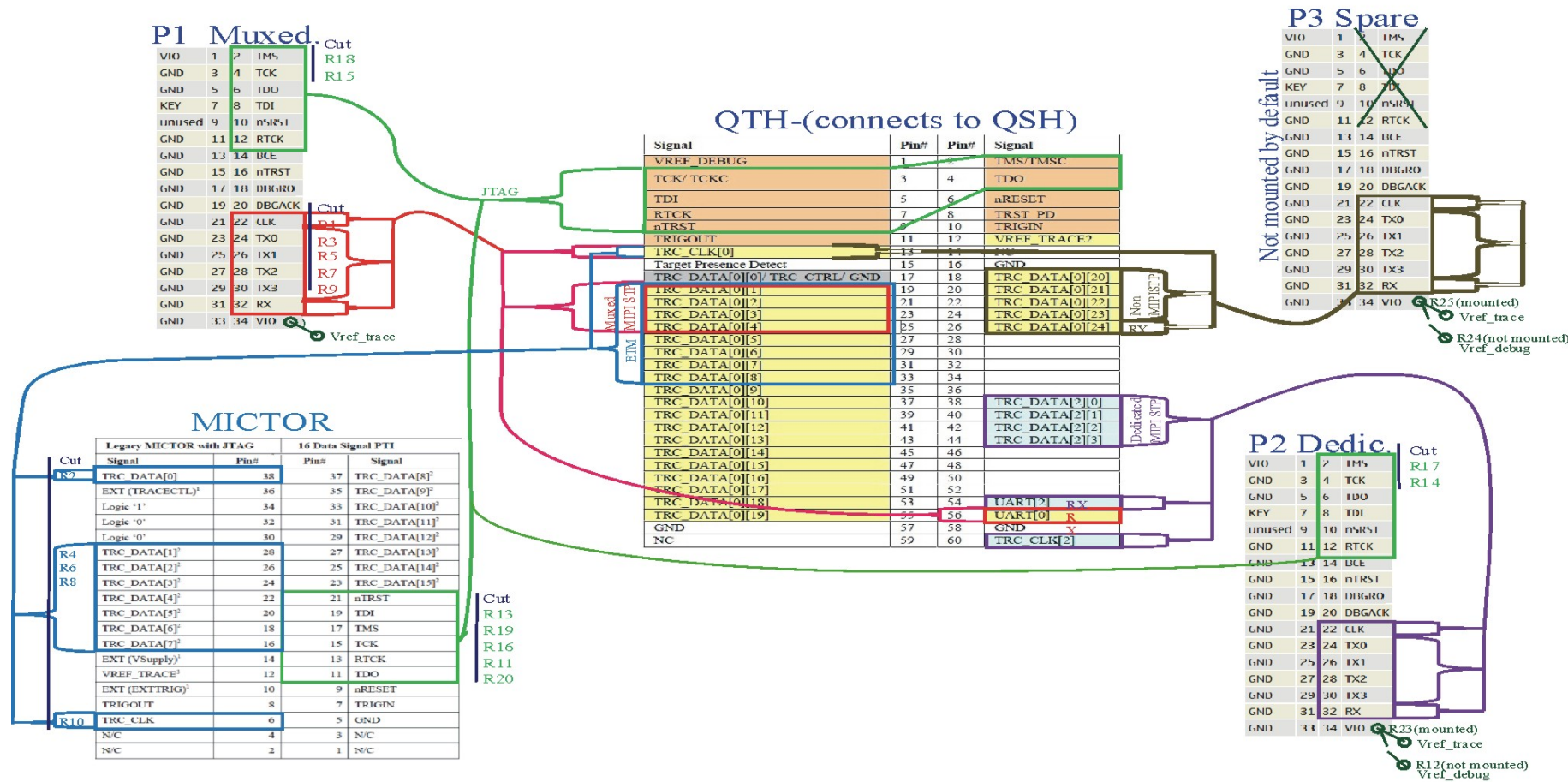

MIPI-60-34-38 schematic diagram

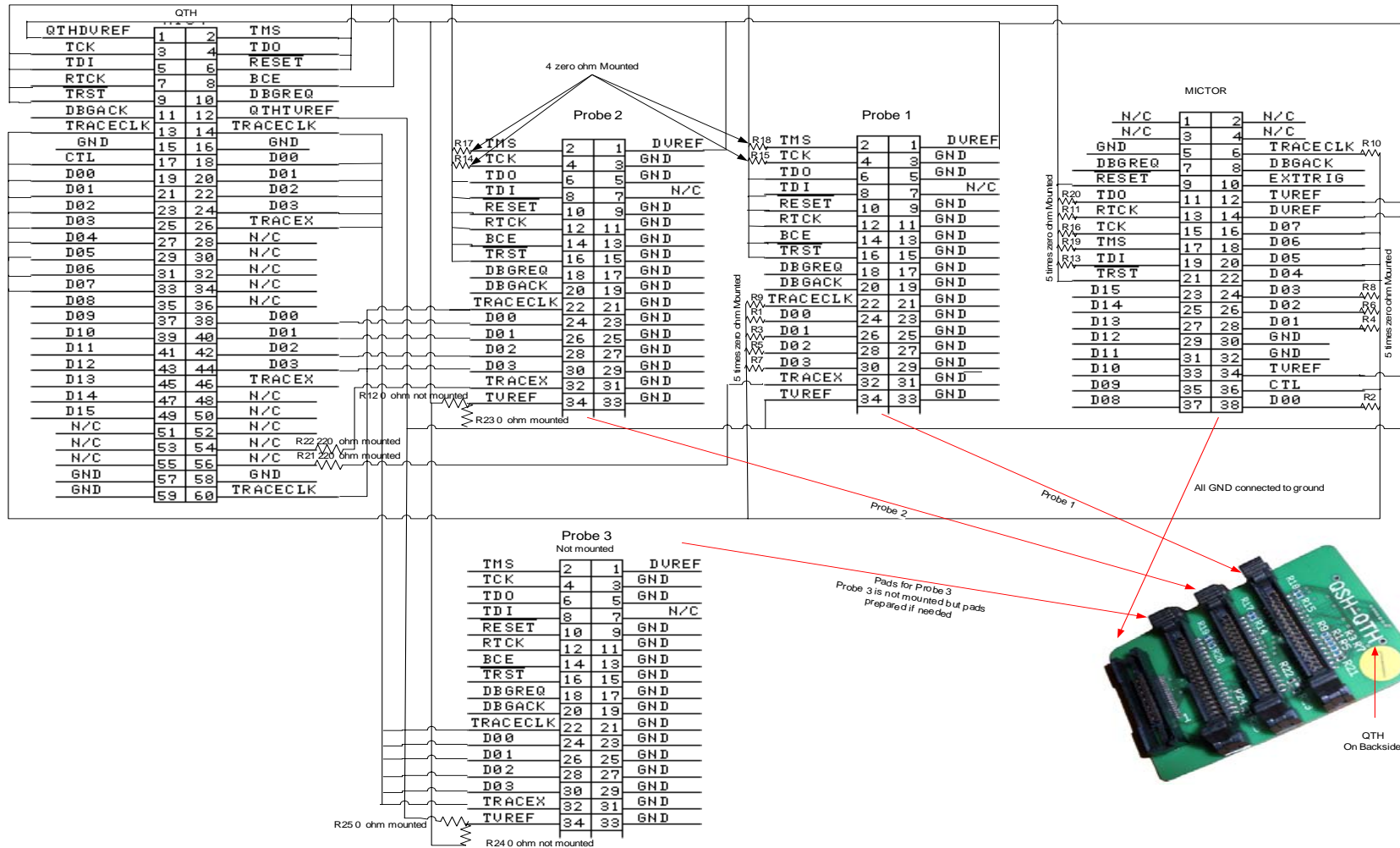

MIPI-60-34-38 front and back sides

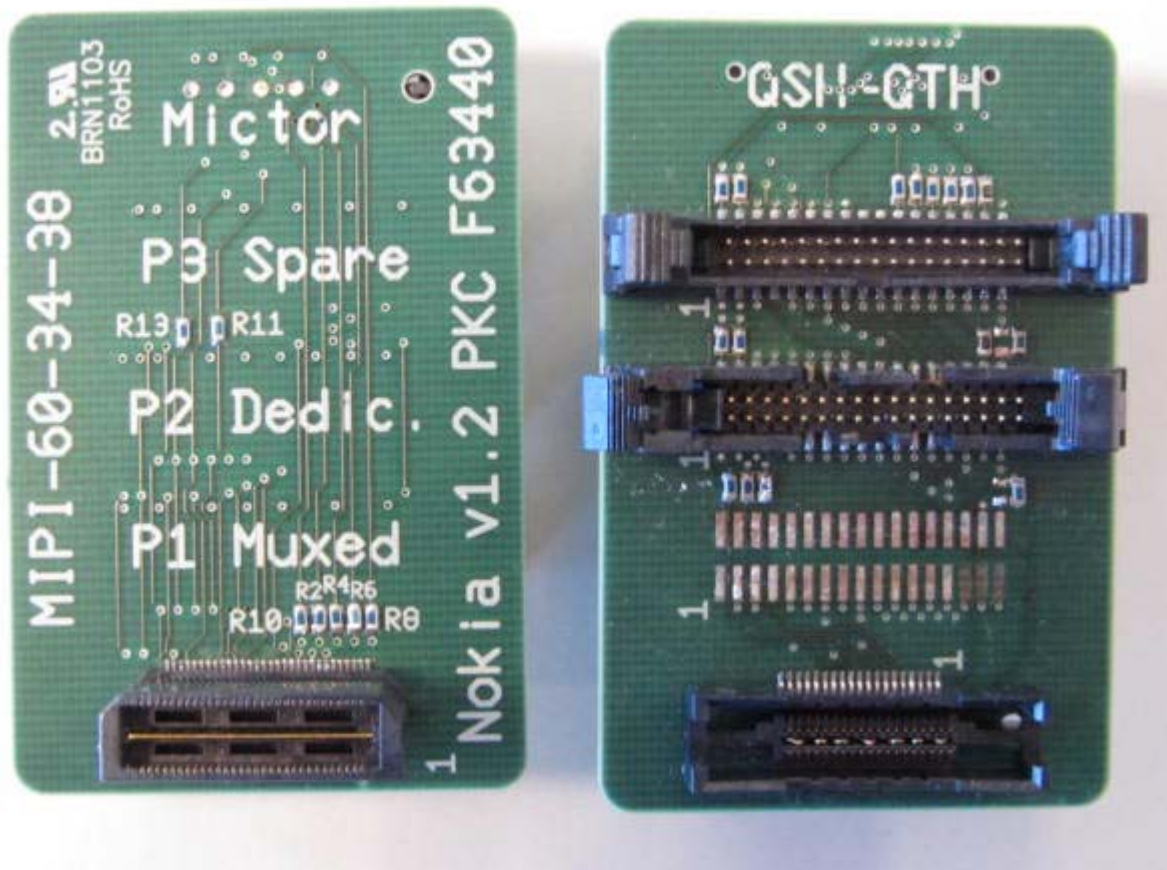

Usage illustrations

The target has a MIPI 60-pin QSH connector, trace signals from muxed pin set are routed to the MIPI 34 cable:

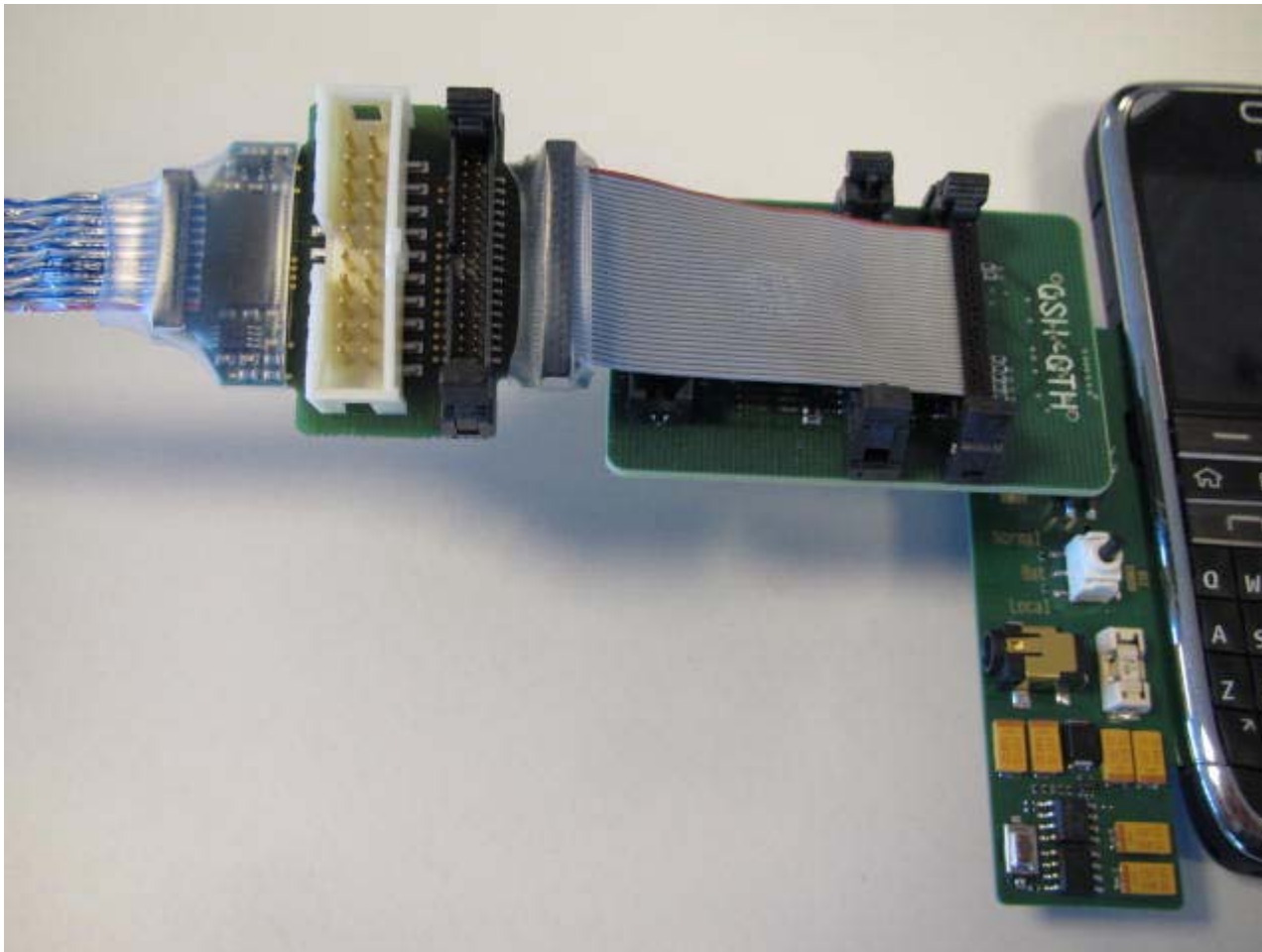

The target has a MIPI 60-pin QSH connector, trace and JTAG signals are routed to Lauterbach preprocessor/debugger via MICTOR connector.

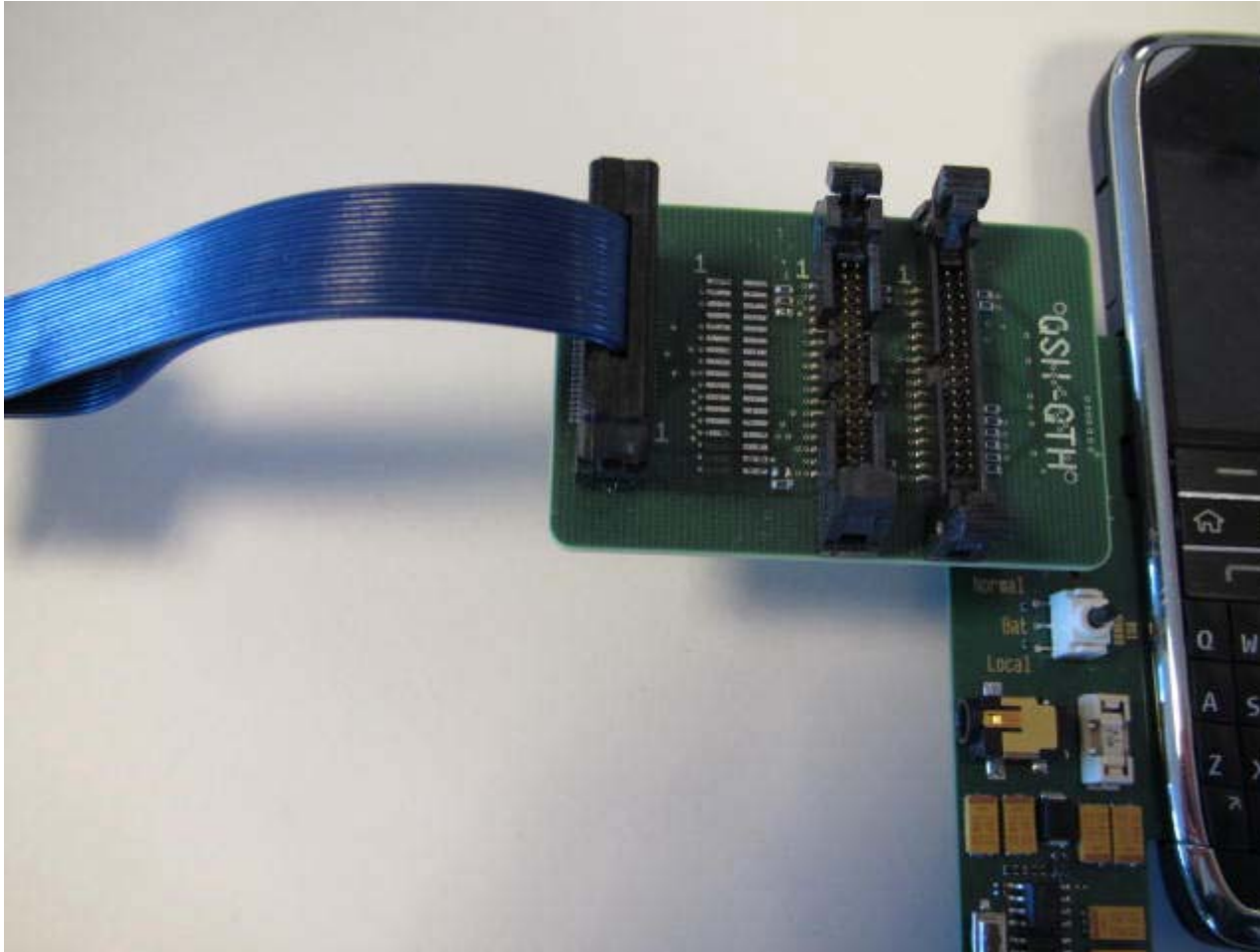

The target has a MIPI 60-pin QSH connector, trace signals from dedicated pin set are routed to MIPI 34 cable. The JTAG is extracted from the MIPI34 cable to Lauterbach debugger:

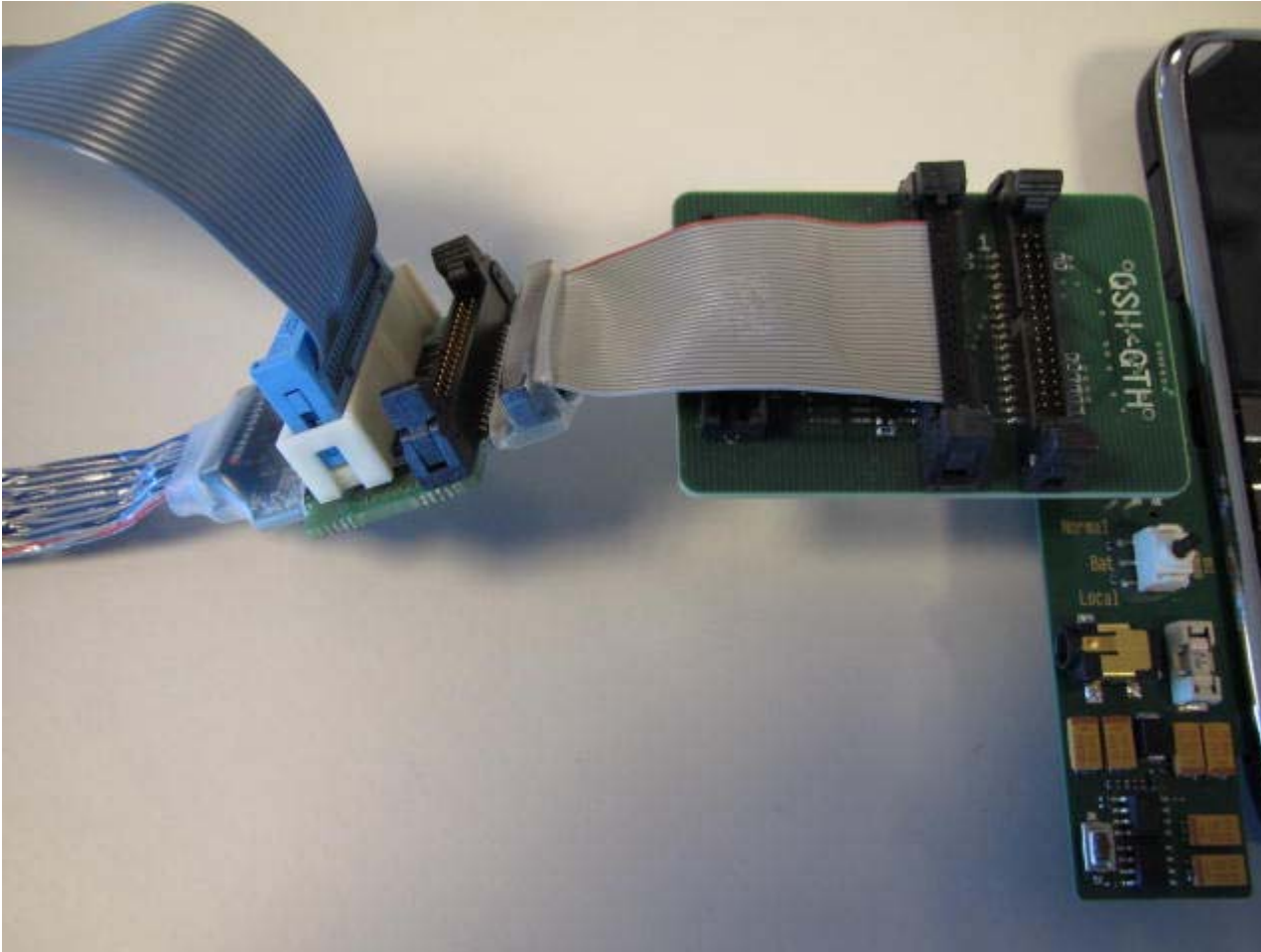

References

1. *MIPI Alliance Recommendation for Test & Debug: Debug and Trace Connectors* stored in file *MIPI_TD_Connectors_1_00_0.pdf*
2. www.Lauterbach.com